

SAMSUNG

VRF

Technical Data Book

**DVM S Water for Europe
(R410A, 50/60Hz, HP/HR)**



Model : Premium energy efficiency Type
Premium compact type

Nomenclature

Outdoor units

Model name

AM	080	M	X	W	A	N	R	/	EU
(1)	(2)	(3)	(4)	(5)	(6)	(7)	(8)		(Buyer)

(1) Classification

AM	DVM
----	-----

(5) Feature1

W	DVM WATER
---	-----------

(2) Capacity

x 1/10 HP (3 digits)

(6) Feature2

A	Standard + General Temp.+ Module
---	----------------------------------

(3) Version

F	2013
H	2014
J	2015
K	2016
M	2017

(7) Rating Voltage

N	3Ø, 380~415V, 50/60Hz
G	3Ø, 380~415V, 50Hz

(4) Product Type

X	Outdoor Unit
N	Indoor Unit

(8) Mode

R	Heat Recovery
H	Heat Pump

2. Specification

Premium energy efficiency Type

Type				DVM S Water	DVM S Water	DVM S Water	DVM S Water	
Model Name	Outdoor unit module 1			AM080MXWA**	AM100MXWA**	AM120MXWA**	AM160MXWA**	
	Outdoor unit module 2			AM080MXWA**	AM100MXWA**	AM120MXWA**	AM080MXWA**	
	Outdoor unit module 3			-	-	-	-	
	Outdoor unit module 4			-	-	-	-	
Power Supply Mode				∅, #, V, Hz	3,4,380-415,50/60	3,4,380-415,50/60	3,4,380-415,50/60	
Mode				-	HEAT RECOVERY	HEAT RECOVERY	HEAT RECOVERY	
Performance	HP	HP		8	10	12	16	
		Ton		6.37	7.96	9.55	12.74	
	Capacity	Cooling	kW		22.4	28.0	33.6	44.8
			Btu/h		76,400	95,500	114,600	152,900
		Heating 2 ¹	kW		25.2	31.5	37.8	50.4
			Btu/h		86,000	107,500	129,000	172,000
		Heating 4 ¹	kW		21.6	25.8	31.1	-
			Btu/h		73,700	88,000	106,500	-
Maximum number of connectable indoor units	Total capacity of the connected Indoor Units	Min.	kW	11.2	14.0	16.8	22.4	
		Max.	kW	29.1	36.4	43.7	58.2	
Power	Power Input	Cooling 3 ¹	kW	3.67	4.87	6	7.34	
		Heating 2 ¹	kW	3.97	5.04	6.25	7.94	
		Heating 4 ¹	kW	4.45	5.43	6.76	-	
	Current Input	Cooling 3 ¹	A	5.9	7.8	9.6	12.4	
		Heating 2 ¹	A	6.4	8.1	10.0	13.2	
	Current	Minimum Ssc value	MVA	3.9	3.9	4.8	7.8	
		MCA	A	16.1	16.1	20.0	31.8	
		MFA	A	20.0	20.0	25.0	40.0	
COP	Cooling 3 ¹		W/W	6.10	5.75	5.60	6.10	
	Heating 2 ¹		W/W	6.35	6.25	6.05	6.35	
	Heating 4 ¹		W/W	4.85	4.75	4.6	-	
Casing	Material	Cabinet	-	Steel plate	Steel plate	Steel plate	Steel plate	
		Base	-	Steel plate	Steel plate	Steel plate	Steel plate	
Compressor	Type	-		Inverter Scroll	Inverter Scroll	Inverter Scroll	Inverter Scroll	
	Output	kW × n		(5.18) x 1	(5.18) x 1	(6.39) x 1	(5.18) x 2	
	Model Name	-		DS-GB052FAVB x 1	DS-GB052FAVB x 1	DS-GB052FAVB x 1	DS-GB052FAVB x 2	
	Oil	Type	-		PVE	PVE	PVE	PVE
Initial Charge		cc		1,100	1,100	1,100	1100 x 2	
Condenser	Type	Type		PHE(Plate Heat Exchanger)	PHE(Plate Heat Exchanger)	PHE(Plate Heat Exchanger)	PHE(Plate Heat Exchanger)	
	Pipe Size	∅, inch		PT1-1/4	PT1-1/4	PT1-1/4	PT1-1/4 x 2	
	Pressure Drop	kPa		22.0	30.0	43.0	22.0 x 2	
	Water Flow Rate	LPM		80.0	96.0	114.0	80.0 x 2	
	Max. Pressure	Mpa		1.96	1.96	1.96	1.96	
Piping Connections	Liquid Pipe	Type		Brazed connection	Brazed connection	Brazed connection	Brazed connection	
		∅, mm		9.52	9.52	12.7	12.7	
		∅, inch		3/8"	3/8"	1/2"	1/2"	
	Gas Pipe (Low pressure gas ref. pipe)	Type		Brazed connection	Brazed connection	Brazed connection	Brazed connection	
		∅, mm		19.05	22.22	28.58	28.58	
		∅, inch		3/4"	7/8"	1 1/8"	1 1/8"	
	Discharge Pipe (High pressure gas ref. pipe)	Type		Brazed connection	Brazed connection	Brazed connection	Brazed connection	
		∅, mm		15.88	19.05	19.05	22.22	
		∅, inch		5/8"	3/4"	3/4"	7/8"	
	Heat insulation				-	Both liquid and gas pipes	Both liquid and gas pipes	Both liquid and gas pipes
	Piping length	ODU-IDU	Max.	m	170 (190)	170 (190)	170 (190)	170 (190)
			After branch	Max.	m	90	90	90
Total piping length		System	Actual	m	500	500	500	
Level difference	ODU-IDU	Outdoor unit in highest position	m	50	50	50	50	
		Indoor unit in highest position	m	40	40	40	40	
Wiring connections	Communication	IDU-IDU	Max.	m	50	50	50	
		Minimum	mm ²	0.75	0.75	0.75	0.75	
		Remark	-	F1, F2	F1, F2	F1, F2	F1, F2	
Refrigerant	Type	-		R410A	R410A	R410A	R410A	
	Factory Charging	kg		5.5	5.8	6.0	11.0	
Sound ³¹	Sound Pressure	Cooling	dB(A)	45	47	47	49	
		Heating	dB(A)	46	49	50	50	
	Sound Power	dB(A)		70	70	70	73	
External Dimension	Net Weight		kg	160	160	160	160 x 2	
	Shipping Weight		kg	167	167	167	167 x 2	
	Net Dimensions (WxHxD)		mm	770 x 1,000 x 545	770 x 1,000 x 545	770 x 1,000 x 545	(770 x 1,000 x 545) x 2	
	Shipping Dimensions (WxHxD)		mm	840 x 1,200 x 620	840 x 1,200 x 620	840 x 1,200 x 620	(840 x 1,200 x 620) x 2	
Operating Temp. Range	Cooling	°C		10.0 - 45.0	10.0 - 45.0	10.0 - 45.0	10.0 - 45.0	
	Heating	°C		10.0 - 45.0	10.0 - 45.0	10.0 - 45.0	10.0 - 45.0	

3. Electric Characteristics

Single

Capacity		Model	Power Supply		Voltage Range		Nominal Running Current [A]		Current [A]	
HP	kW		Hz	Voltage	Min. (-10%)	Max. (+10%)	Cooling	Heating	MCA	MFA
8	22.4	AM080MXWANR	50/60	380~415	342	456	6.2	6.6	16.1	20
10	28.0	AM100MXWANR	50/60	380~415	342	456	8.1	8.4	16.1	20
12	33.6	AM120MXWANR	50/60	380~415	342	456	10.3	10.4	20.0	25
20	56.0	AM200MXWANR	50/60	380~415	342	456	17.3	17.4	31.8	40
30	84.0	AM300KXWANR	50/60	380~415	342	456	26.4	26.5	48.1	63.1

Module (Premium energy efficiency type)

Capacity		Model	Power Supply		Voltage Range		Nominal Running Current [A]		Current [A]	
HP	kW		Hz	Voltage	Min. (-10%)	Max. (+10%)	Cooling	Heating	MCA	MFA
16	44.8	AM160MXWANR2	50/60	380~415	342	456	12.4	13.2	32.2	40
18	50.4	AM180MXWANR2	50/60	380~415	342	456	14.3	15	32.2	40
22	61.6	AM220MXWANR2	50/60	380~415	342	456	18.4	18.8	36.1	40
24	67.2	AM240MXWANR2	50/60	380~415	342	456	20.6	20.8	40.0	50
26	72.8	AM260MXWANR2	50/60	380~415	342	456	20.5	21.6	48.3	63
28	78.4	AM280MXWANR2	50/60	380~415	342	456	23.5	24	47.9	63
30	84.0	AM300MXWANR2	50/60	380~415	342	456	25.4	25.8	47.9	63
32	89.6	AM320MXWANR2	50/60	380~415	342	456	27.6	27.8	51.8	63
34	95.2	AM340MXWANR2	50/60	380~415	342	456	28.7	29.2	56.1	63
36	100.8	AM360MXWANR2	50/60	380~415	342	456	29.7	30.6	64.0	75
38	106.4	AM380MXWANR2	50/60	380~415	342	456	31.6	32.4	64.0	75
40	112.0	AM400MXWANR2	50/60	380~415	342	456	34.6	34.6	63.6	75
42	117.6	AM420MXWANR2	50/60	380~415	342	456	35.7	36.2	67.9	75
44	123.2	AM440MXWANR2	50/60	380~415	342	456	37.9	38.2	71.8	80
48	134.4	AM480MXWANR2	50/60	380~415	342	456	40.8	41.4	79.7	90
50	140.0	AM500MXWANR2	50/60	380~415	342	456	42.7	43.2	79.7	90
52	145.6	AM520MXWANR2	50/60	380~415	342	456	44.9	45.2	83.6	100
60	168.0	AM600MXWANR2	50/60	380~415	342	456	51.9	52.2	95.4	125

4. Dimensional Drawing

AM080/100/120MXWA** (8, 10, 12HP)

Unit : mm

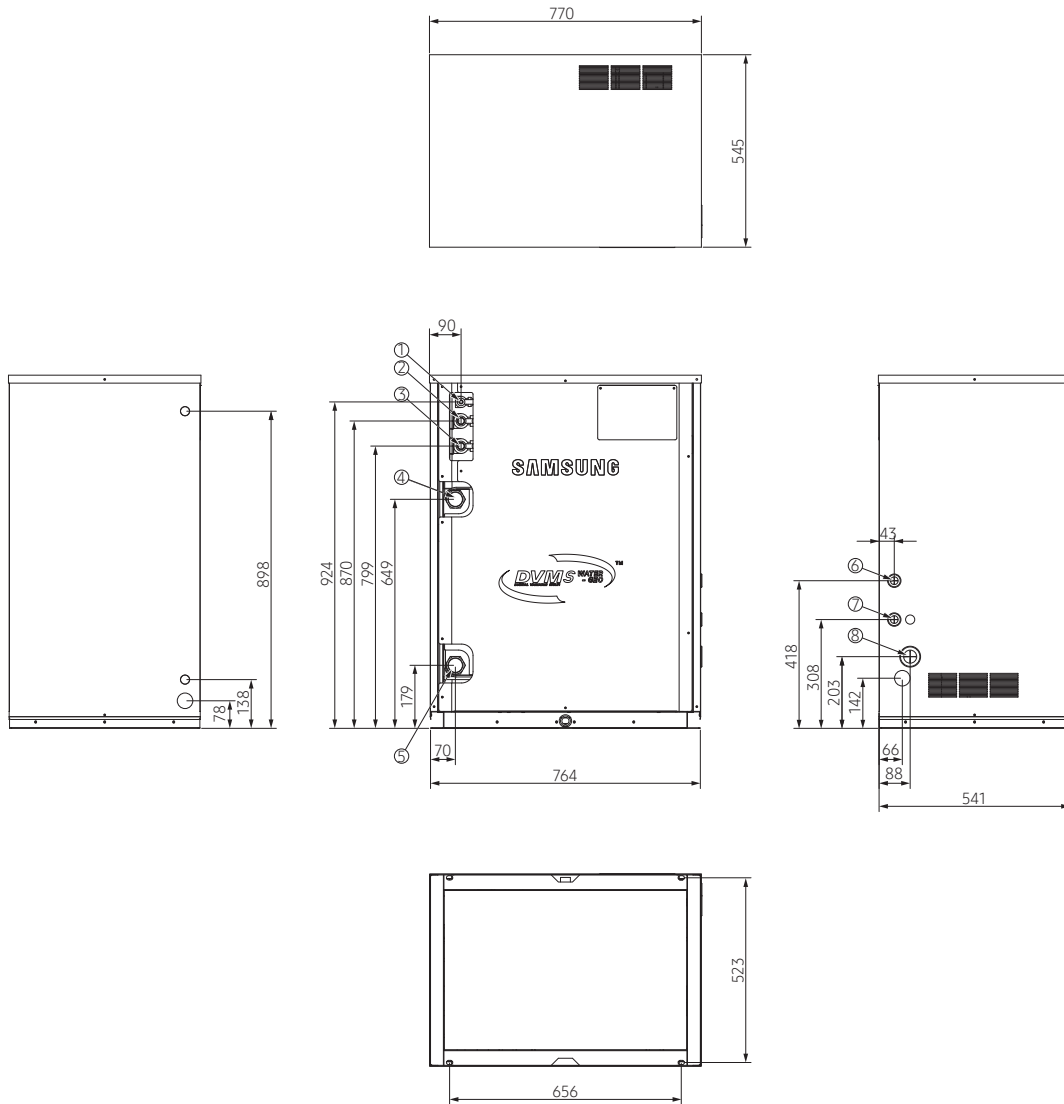

No.	Name	Description			No.	Name	Description		
		8HP	10HP	12HP			8HP	10HP	12HP
①	Liquid ref. pipe	9.52 (3/8")	9.52 (3/8")	12.70 (1/2")	⑤	Water inlet pipe	PT1-1/4		
②	High pressure gas ref. pipe	15.88 (5/8")	19.05 (3/4")	19.05 (3/4")	⑥	Communication wiring	-		
③	Low pressure gas ref. pipe	19.05 (3/4")	22.22 (7/8")	28.58 (1 1/8")	⑦	External contact wiring	-		
④	Water outlet pipe	PT1-1/4			⑧	Power wiring	-		

6. Electrical Wiring Diagram

AM080MXWA**~AM200MXWA** (8~20HP)**

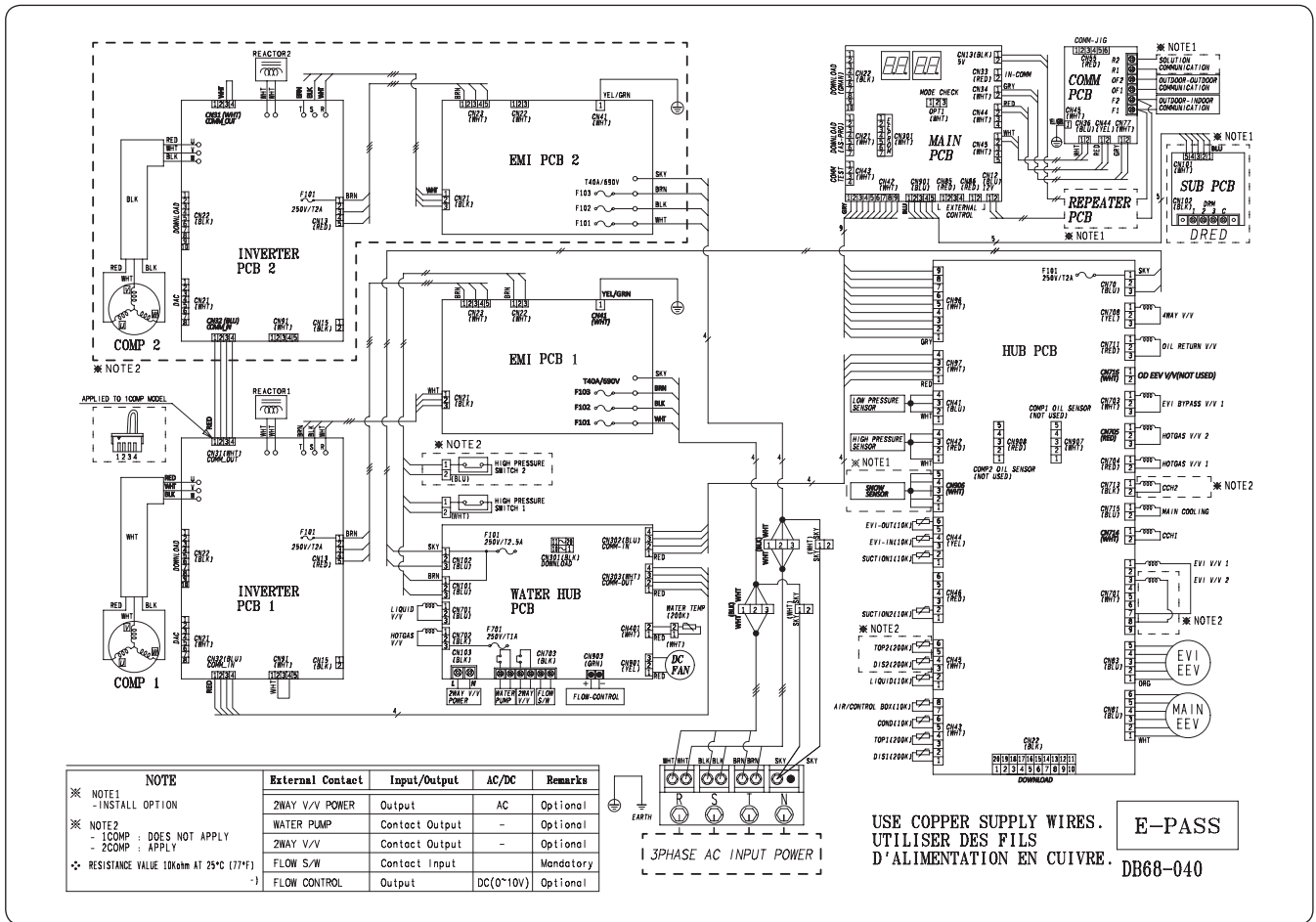

INVERTER PCB1	Printed circuit board (Inverter PBA1)	EEV1	Electrical Expansion Valve 1	HOTGAS V/V1	Solenoid Valve (Hot Gas Bypass1)
INVERTER PCB2	Printed circuit board (Inverter PBA2)	EEV2	Electrical Expansion Valve 2	HOTGAS V/V 2	Solenoid Valve (Hot Gas Bypass2)
EMI PCB1	Printed circuit board (Noise Filter1)	EVI-OUT (10K)	Temp. Sensor (EVI-out_10kohm)	EVI BYPASS V/V1	Solenoid Valve (EVI Bypass)
EMI PCB2	Printed circuit board (Noise Filter2)	EVI-IN (10K)	Temp. Sensor (EVI-in_10Kohm)	OIL RETURN V/V	Solenoid Valve (Accumulator Oil Return)
WATER HUB PCB	Printed circuit board (Water related load control)	COMP SUCTION1 (10K)	Temp. Sensor (COMP Suction TEMP.1_10Kohm)	4WAY V/V	Solenoid Valve (4Way Valve)
MAIN PCB	Printed circuit board (main)	COMP SUCTION2 (10K)	Temp. Sensor (COMP Suction TEMP.2_10Kohm)	CCH1	Crank Case Heater (COMP1)
HUB PCB	Printed circuit board (hub)	CONTROL BOX TEMP	Temp. Sensor (Inside TEMP. of Control Box_10Kohm)	CCH2	Crank Case Heater (COMP2)
COMM PCB	Printed circuit board (Communication)	CONDENSER OUT (10K)	Temp. Sensor (Condenser Out_Temp_10Kohm)	MAIN COOLING	Solenoid Valve (Main Cooling)
COMP1	Motor (Compressor1)	COMP TOP1 (200K)	Temp. Sensor (Compressor1_200Kohm)	F101 250V/T2A	FUSE (INVERTER PBA)
COMP2	Motor (Compressor2)	COMP TOP2 (200K)	Temp. Sensor (Compressor2_200Kohm)	690V/T40A	FUSE (NOISE FILTER)
EVI V/V1	Solenoid Valve (EVI1)	DISCHARGE1 (200K)	Temp. Sensor (COMP Discharge.1_200Kohm)	F101 250V/T2.5A	FUSE (WATER HUB)
EVI V/V2	Solenoid Valve (EVI2)	DISCHARGE2 (200K)	Temp. Sensor (COMP Discharge.2_200Kohm)	F701 250V/T1A	FUSE (WATER HUB)
EVI EEV	Enhanced Vapor Injection Electrical Expansion Valve	LIQUID TUBE (10K)	TEMP. Sensor (Liquid Tube Temp. 10Kohm)		

NOTE

- This wiring diagram applies only to the water-cooled DVM S Water.
- Colors BLK: black, RED: red, BLU: blue, WHT: white, YEL: yellow, BRN: brown, SKY: skyblue
- When operating, don't short circuit the protection device (High Pressure switch)
- For connection wiring indoor-outdoor transmission F1-F2, outdoor-outdoor transmission OF1-OF2, refer to the installation manual.
- ⊕ Protective earth (screw), □□□□ connector, $\frac{N}{\text{---}}$: The wire quantity

7. Sound Level

Summary

Single

Capacity		Model	Sound Pressure dB(A)		Sound Power (dBA)
HP	KW		Cooling	Heating	
8	22.4	AM080MXWANR	45	46	70
10	28.0	AM100MXWANR	47	49	70
12	33.6	AM120MXWANR	47	50	70
20	56.0	AM200MXWANR	50	52	73
30	84.0	AM300KXWANR	56	58	75

Module (Premium energy efficiency type)

Capacity		Model	Sound Pressure dB(A)		Sound Power (dBA)
HP	KW		Cooling	Heating	
16	44.8	AM160MXWANR2	49	50	73
18	50.4	AM180MXWANR2	50	51	73
22	61.6	AM220MXWANR2	51	53	73
24	67.2	AM240MXWANR2	51	54	73
26	72.8	AM260MXWANR2	51	53	75
28	78.4	AM280MXWANR2	52	53	75
30	84.0	AM300MXWANR2	52	54	75
32	89.6	AM320MXWANR2	52	55	75
34	95.2	AM340MXWANR2	52	55	75
36	100.8	AM360MXWANR2	53	54	76
38	106.4	AM380MXWANR2	53	55	76
40	112.0	AM400MXWANR2	54	56	76
42	117.6	AM420MXWANR2	54	56	76
44	123.2	AM440MXWANR2	54	56	76
48	134.4	AM480MXWANR2	54	56	77
50	140.0	AM500MXWANR2	54	56	77
52	145.6	AM520MXWANR2	54	57	77
60	168.0	AM600MXWANR2	55	57	78

9. Piping Diagram

AM080/100/120MXWA**

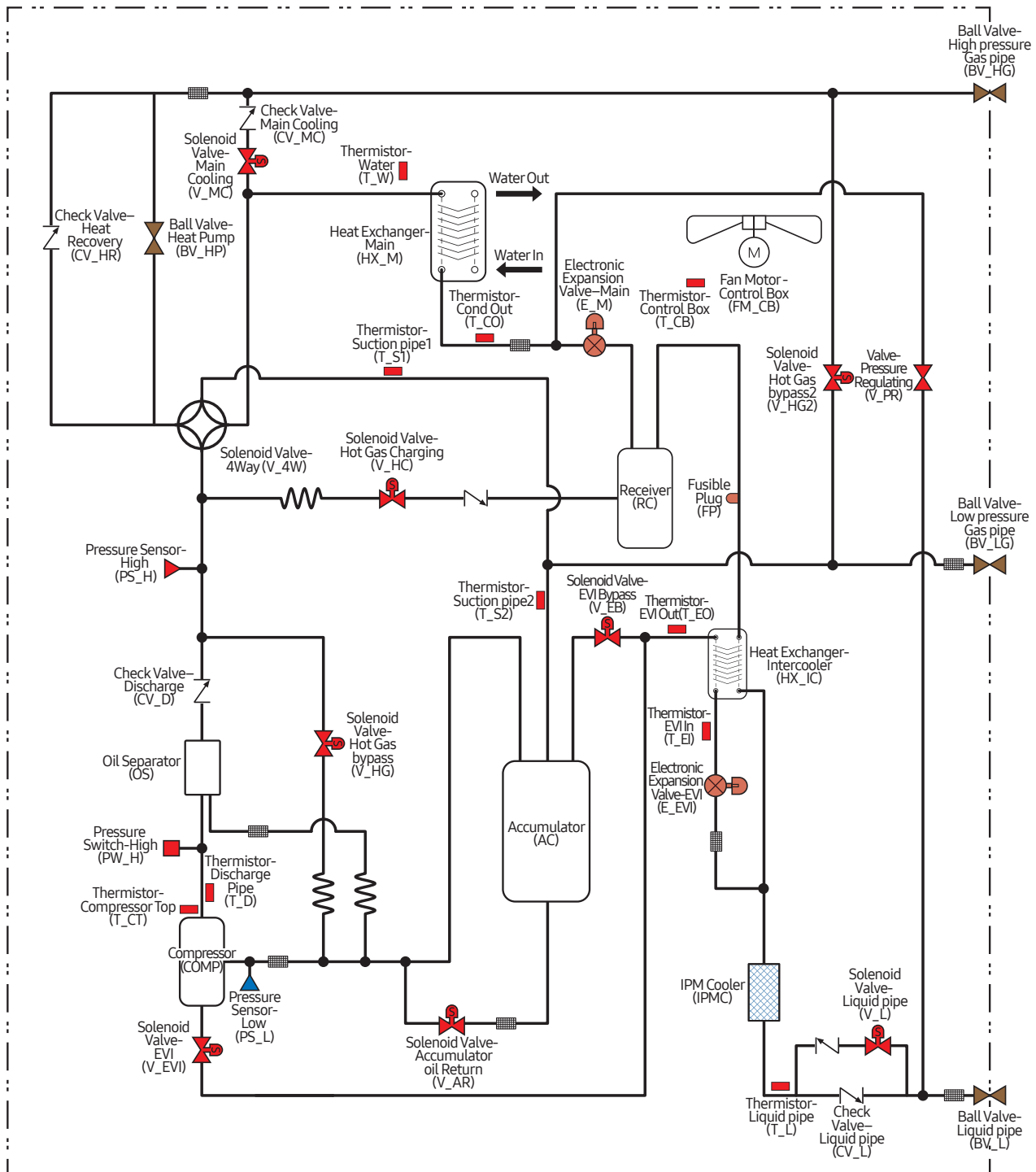

2021.02
Ver.1.2

Samsung Electronics Co., LTD.

Head Office (Suwon Korea) 129, Samsung-Ro, Yeongtong-Gu, Suwon City, Gyeonggi-Do, Korea 16677
Website : www.samsung.com, <https://partnerhub.samsung.com> Email : airconditioner@samsung.com
Images and data in this book may subject to change without prior notice.